

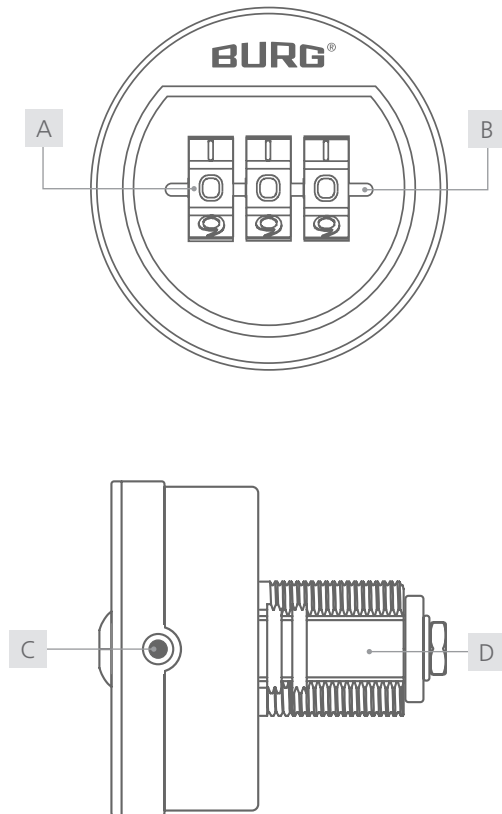

sPinLock100
Operating Manual

sPinLock100



- A number wheels
- B guide line
- C opening for key tool
- D stator

Content

General.....	2
Technical data.....	3
Scope of delivery.....	3
Optional accessories.....	3
Features.....	3
Product dimensions.....	3
Mounting dimensions.....	3
Functional description.....	3
Configuration.....	4
Operation.....	4
Contact.....	4

General

The latest version of this guide is available at:
www.burg.de

Important: Please observe all warnings and read the entire operating manual before starting the configuration.

Factsheet

Front view



Back view



Technical Data

Dimension	Ø 46 mm x 19 mm
Material	Housing: plastic Stator: zamak
Mode	Private mode
Number wheels	3
Code combinations	999
Locking direction	Left (90°), door hinge: DIN right
Mounting hole	16 mm x 19 mm
Lock attachment	M19 nut (1x)
Max. door thickness	1 mm to 11 mm
Cam type	B
Code (default)	0-0-0

Product Dimensions

Front view

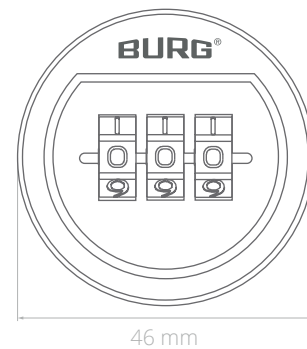

Side view

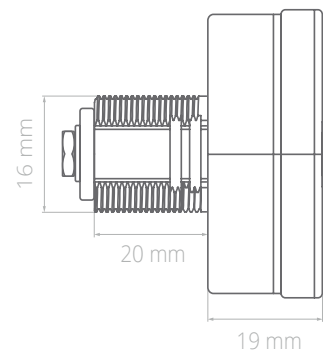

Scope of Delivery

- 1x locking system
- 1x cam fixing screw (M4 x 8mm) with washer
- 1x M19 nut
- 1x key tool

Optional Accessories

- code finding tool

Features

- can be used in wooden and metal doors (indoor)
- compact dimensions
- simple installation (retro-fit)
- intuitive and easy to use
- with integrated function for code finding
- up to 999 possible code combinations
- simple code configuration

Mounting Dimensions

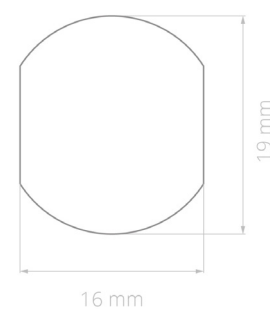

Functional Description

Mode: fixed assigned authorization (private mode)

In this mode, a code is preset with which the lock can be operated. This mode is suitable for user groups where the usage rights should not change permanently, e.g. for an office cabinet. The lock can only be operated with the preset code.

Key tool

With the key tool the user code can be set. For this configuration step the lock must be open.

Code finding tool

The code finding tool can be used to open the lock, e. g. if the code is lost. The valid code can be read during this process.

Note: the code finding tool is not included in the scope of delivery and must be ordered separately.

Configuration

1 Set the code

1. Set the valid code using the number wheels (factory setting 0-0-0).
2. Press the key tool into the opening on the side of the lock (see illustration) and hold:

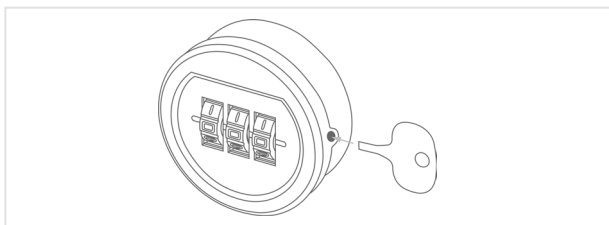

3. Set the new code using the number wheels.
4. Remove the tool.

2 Code finding

1. Start with the right-hand number wheel. Position the code finding tool to the right of the number wheel. Slide it between the number wheel and the housing:

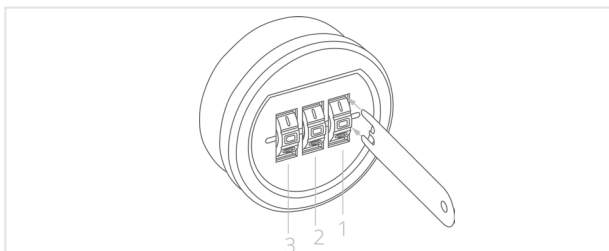

2. Carefully turn the number wheel until the tool clicks into place. Remove the tool.
3. Repeat the process for the other number wheels (from right to left).
4. Read the valid code. The lock is now unlocked.

Operation

1 Unlock

1. Set the valid code using the number wheels.
2. Turn the lock 90° to the right and pull the door open.

2 Lock

1. Close the door and turn the lock to the starting position.
2. Turn the number wheels.

Contact

BURG Lüling GmbH & Co. KG

Volmarsteiner Str. 52
58089 Hagen (Germany)
+49(0)23 35 63 08-0

info@burg.de
www.burg.de